



ASQ10 WiFi Speaker

ASQ10 WiFi Speaker is an indoor wall-mounted IP speaker, available in two models: ASQ10-SW and ASQ10-TW. Both models are equipped with a built-in microphone, allowing operators to engage in two-way communication. Additionally, ASQ10-TW model features a programmable LCD screen that displays the date and time when in standby mode, eliminating the need for a separate clock system. ASQ10-TW also supports customizable text display for daily notifications, announcements, and alerts in emergencies. Its display-flashing feature enhances visibility, ensuring that important information is noticed promptly. This makes it ideal for use in business, education, healthcare, and other scenarios.

Applicable Scenarios



Schools



Health Care



Office Buildings



Hotel Lobbies



Airports



Pharmacies



Banks



Residential Buildings



Restaurants



Hospitals

Features



HD Audio

ASQ10 speaker is equipped with a 4.5" full-range driver unit, delivering high-definition sound quality. It supports background music playback, real-time announcements, two-way communication, emergency alerts, and zoned broadcasting.



Microphone

ASQ10 speaker features a built-in microphone, when used with a call button, it allows initiating two-way communication from the ASQ10 to request help or report emergencies.



Peripheral Integration

ASQ10 speaker supports peripheral integration and can connect to external devices such as strobes, call buttons, and door magnets, enabling a broader range of functional applications.



SIP Integration

ASQ10 speaker supports the standard SIP protocol and can be integrated with the IP Audio Center or third-party standard SIP servers such as IP-PBX system.



ONVIF Compatible

ASQ10 speaker is compatible with ONVIF supported Video Management Software (VMS), enabling collaboration with IP cameras for functions such as paging, emergency notifications, real-time announcements, and event linkage, enhancing both security and functionality.



PoE+ Support

ASQ10 speaker supports PoE+, allowing easy connection to the local network using only a CAT 5/6 cable. If necessary, it can also be powered through a standard power supply.



Clock System

The LCD screen of the ASQ10-TW can display time information while in standby mode and supports time synchronization with an NTP server or a PC, eliminating the need for a separate clock system.



Customizable Display Text

The programmable LCD screen of the ASQ10-TW supports customizable text, background colors, and display flashing, allowing different scenario presets to be created. The display can be triggered by various methods, making it ideal for daily notifications, announcements, and emergency alerts.



Caller ID Display

The LCD screen of the ASQ10-TW supports multiple caller ID display modes, allowing it to be configured to show the caller's name, number, or both. This helps quickly identify the caller, improving efficiency and communication accuracy.

Specifications

Audio	
Speaker Component	4.5" Full Range Driver Unit
Sensitivity	91dB/1m/1W
Max Sound Pressure Level	101dB
Frequency Response	70Hz~20KHz
Coverage Pattern	90°H 50°V 30m ²
Amplifier	Single Channel Class-D Topology
THD	<0.1%
Rated Power	8Ω 10W
Network Audio Codecs	G.722, G.711 A-law, G.711 U-law, Opus
Microphone	
Directivity	Omni-Directional
Sensitivity	-36±2dB
Impedance	2.2kΩ (Max)
S/N Ratio	65dB
Maximum Input Sound Pressure Level	110dB THD≤3%
Standard Operating Voltage	2.0 Vdc
Current Consumption	500μA (Max)
Display	
Display Type	High Resolution Back-Lit Color LCD Display
Display Color	16-bit RGB
Brightness	600 cd/m ²
Resolution	1920*480
Viewable Dimensions	8.63" x 2.16" (219.1mm x 54.9mm)
Text Display	Configured via WebGUI
Network	
Ethernet	IEEE 802.3 10/100 Base-T
PoE	IEEE 802.3 at Compliant
Supported Protocols	SIP(RFC3261), HTTP, TCP/IP, SSL, DNS, SNTP, NTP, RTSP, RTP, RTCP, TCP, UDP, MQTT, ICMP, DHCP, ARP, SSH
IP Addressing	DHCP / Static
Wi-Fi Compatible	Supported
Wi-Fi Standards	IEEE 802.11 b/g/n (2.4 GHz) IEEE 802.11 a/n (5 GHz, 2x2 MIMO)
Frequency Range	2.400 GHz ~ 2.497 GHz (2.4 GHz ISM Band) 4.900 GHz ~ 5.845 GHz (5.0 GHz ISM Band)

Mechanical Properties	
Memory	128MB RAM, 256MB Flash
AC Power Input	PoE+ and External 24VDC
Casing Material	Cold Rolled Steel Finished in Textured White Epoxy
Mounting Method	Wall Mounted
Color	White
Weight	SQ10-B: 3.25kg(7.17lb) SQ10-T: 3.5kg(7.72lb)
Dimensions	11.81" x 11.81" x 3.62" (300mm x 300mm x 92mm)
Environmental	
Installation Environment	Indoor
Operating Temperature	-20°C - 50°C (-4°F - 122°F)
Storage Temperature	-40°C - 70°C (-40°F - 158°F)
Humidity	10% - 95% RH Non-condensing
Approvals	
Approvals	EN 55032:2015, EN 55035:2017, EN 61000-3-2:2014, EN 61000-3-3:2013, EN 62368-1:2014+A11:2017, FCC Part 15B Class A
Warranty Coverage	
Warranty Period	2 Year

Frequency Response Curve

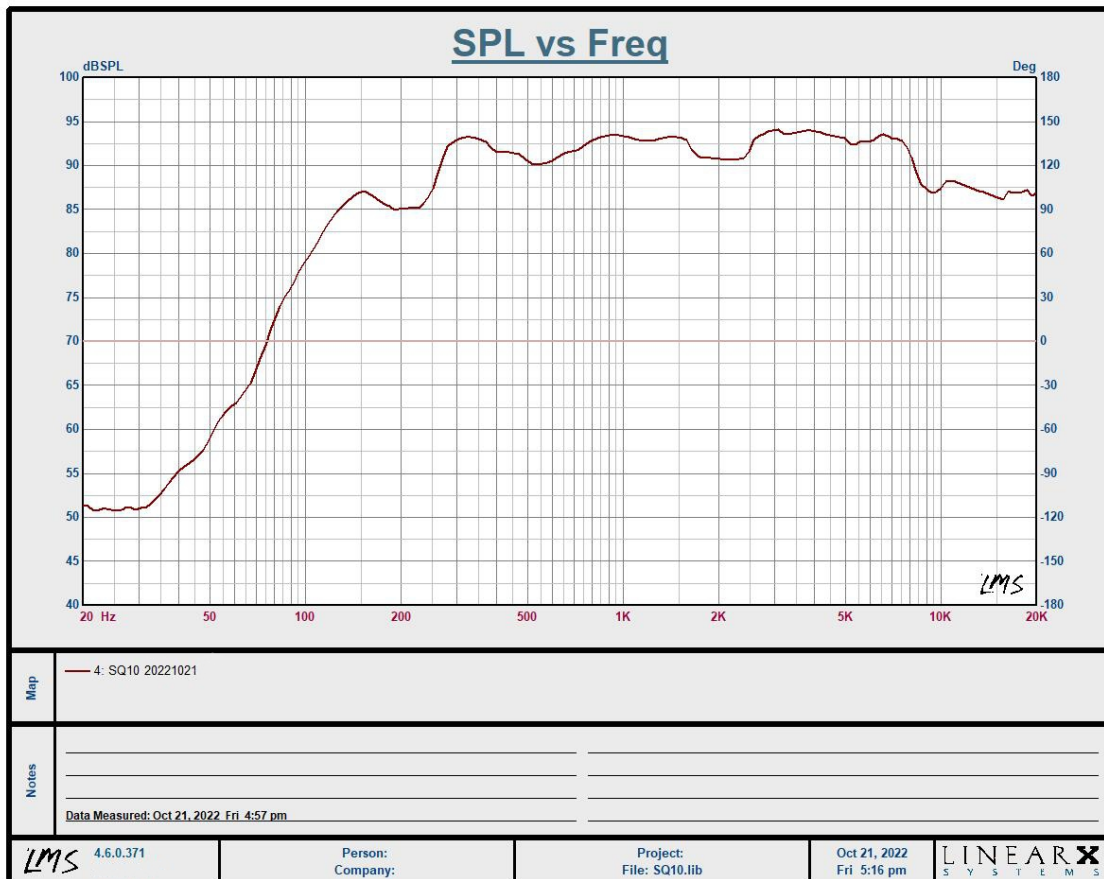

Dimensioning

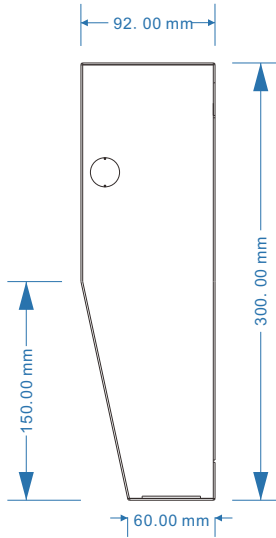

Side

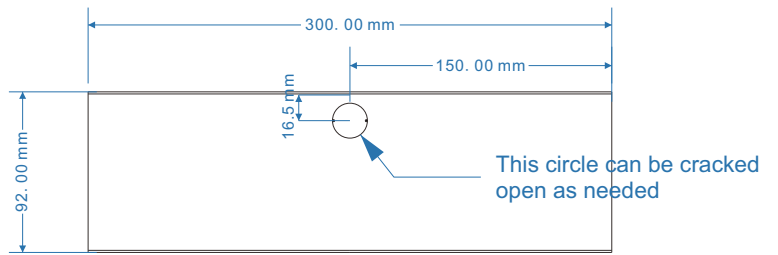

Top

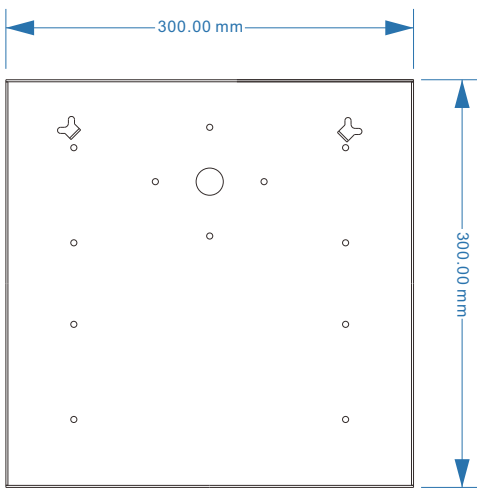

Rear panel-back

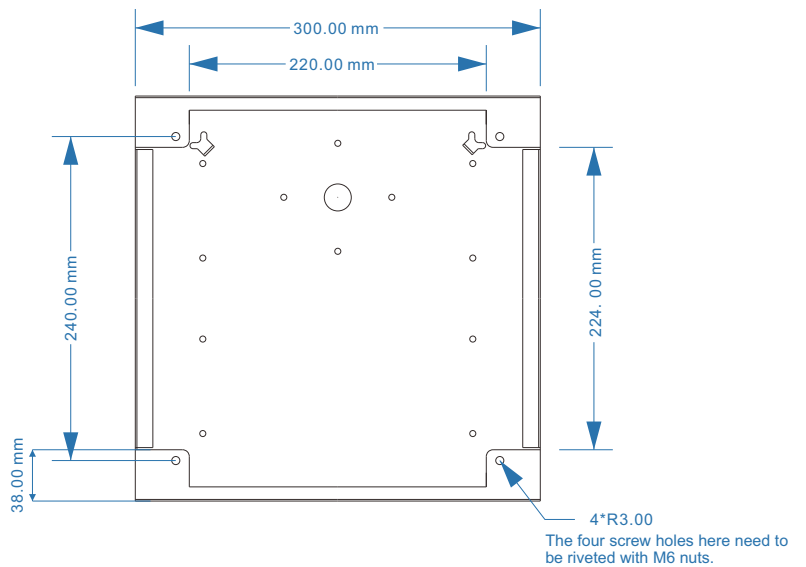

Rear panel-front

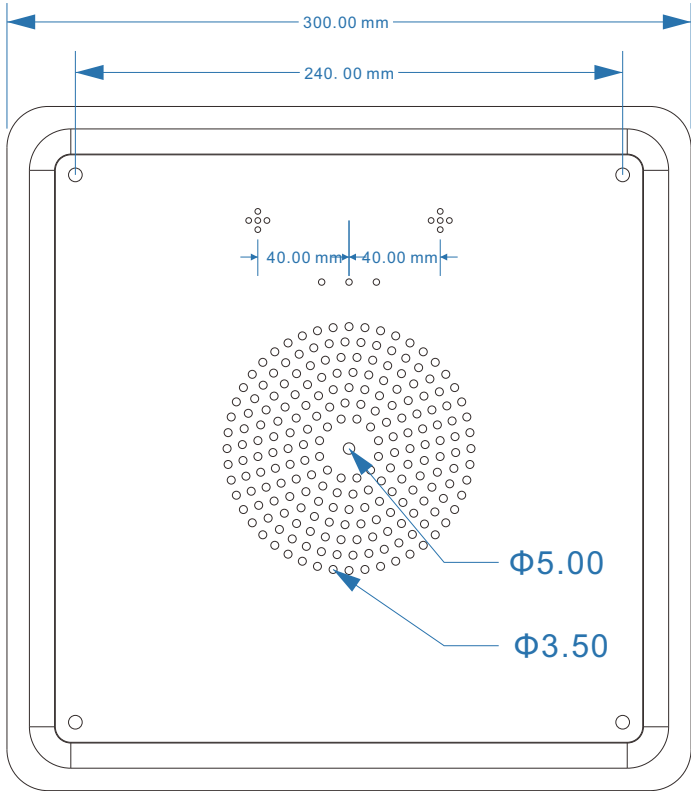

(ASQ10-SW)

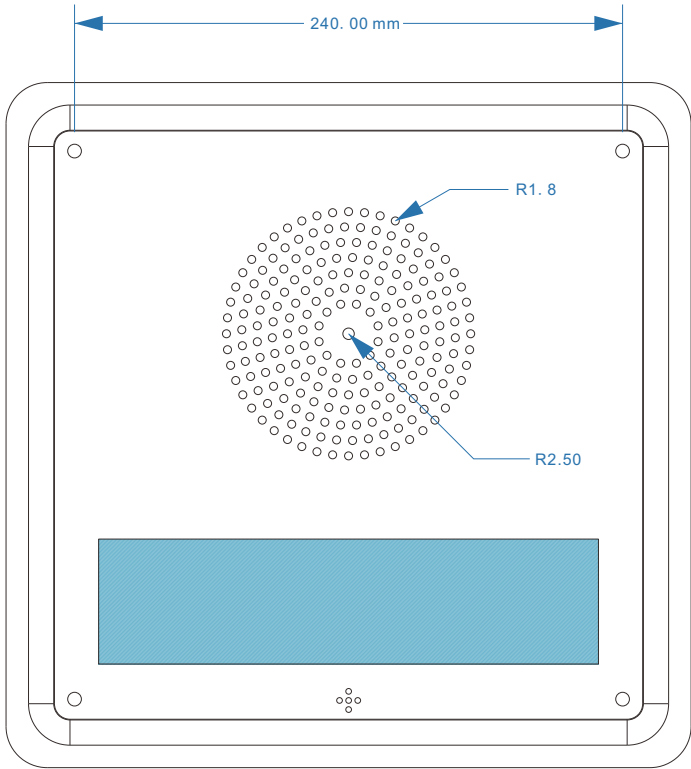

(ASQ10-TW)

